

TwinBus IP

REG Bus Filter

Installation Guide

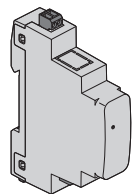

RGE2057101

For your safety

⚠️ ⚠️ DANGER

HAZARD OF ELECTRIC SHOCK, OR ARC FLASH

Safe electrical installation must be carried out only by skilled professionals. Skilled professionals must prove profound knowledge in the following areas:

- Connecting to installation networks
- Connecting several electrical devices
- Laying electric cables
- Safety standards, local wiring rules and regulations

Failure to follow these instructions will result in death or serious injury.

About this document

In this document you will find all information for safe installation.



For further product information, follow the QR Code.



<https://www.merten.de/profibereich/service/downloads.html>

Scope of supply

REG Bus Filter, installation guide

Introduction to the TwinBus IP REG Bus Filter

The TwinBus IP REG Bus Filter (hereinafter referred to as the **bus filter**) is designed for isolating the power supply from the bus.

Device overview

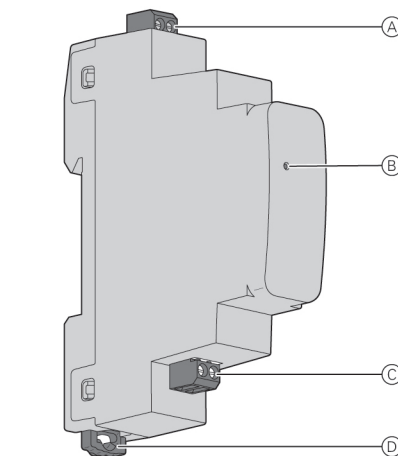

- (A) Port In A Bus +, In B Bus -
- (B) LED green
- (C) Port Out A Bus +, Out B Bus -
- (D) Disassembly clip

The green LED indicates that the supply voltage from the REG power supply is present.

The right place to install

The bus filter is mounted on a TH 35/7.5 or TH 35/15 standard DIN rail.

When choosing the installation location, the maximum cable length must be observed. The following table shows the maximum cable length between the bus filter and the system components.

	Group 0.8 mm Cable	Group 0.6 mm Cable	Group 0.5 mm Cable
REG power supply	< 1 m	< 1 m	< 1 m
Door station	80 m	60 m	50 m
Video indoor station	80 m	80 m	50 m

Group 0.8 mm cable:

YR 2x0.8 mm, J-Y(ST)Y 2x2x0.8 mm, A-2Y(L)2Y 2x2x0.8 mm, CAT5e / CAT6 0.8 mm

Group 0.6 mm cable:

A-2Y(L)2Y 2x2x0.6 mm, J-Y(ST)Y 2x2x0.6 mm, CAT5e / CAT6 0.8 mm

Group 0.5 mm cable:

CAT5e / CAT6 0.5 mm

When using a shielded cable, the shield must not be connected.

Installation

⚠️ WARNING DANGER TO LIFE DUE TO ELECTRIC SHOCK

- Only mount devices with basic insulation next to the device.

Failure to comply with this instruction may result in death or serious injury.

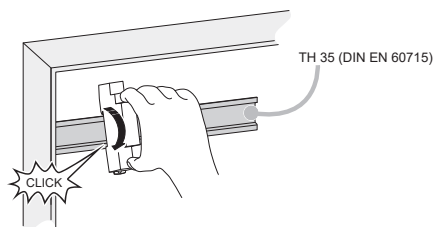

- 1 Attach bus filter to DIN rail.

Circuit diagram

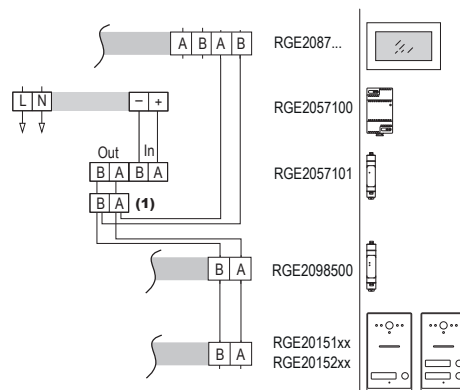

- (1) Terminal strip

Technical data

Performance data

Input voltage	SELV DC 24 V
Current consumption	<0.05 A

Environmental conditions

Ambient temperature	-10 °C ... 55 °C
Humidity (max)	96 %

Dimensions and weight

Dimension (W x H x D)	17.8 x 99.3 x 66.1 mm
Weight	61.5 g
Space requirement on the DIN rail	1 TE

Connection terminal

Clamping range (conductor diameter)	4x 0.5 mm (AWG 24) solid 3x 0.6 mm (AWG 22) solid 2x 0.8 mm (AWG 20) solid Copper-clad aluminum conductors must not be used.
-------------------------------------	---

Nominal torque 0.2 Nm

Housing insulation

Basic insulation to neighboring DIN rail devices

Protection class

The device complies with the IP30 protection class if it is installed in a distribution cabinet with at least IP30.

WEEE



Dispose of the device separately from household waste at an official collection point. Professional recycling protects people and the environment against potential negative effects.

**Schneider Electric GmbH c/o
Ritto**

Gothaer Straße 29, 40880 Ratingen

Customer Service:

Telephone: +49 211 7374 8008

www.ritto.de

© 2022 Schneider Electric, all rights reserved